

**25+**

Years in Training,  
Coaching &  
Research

Author of

**3 Books**

**2** Copyrights

Coached **100+**  
National & International  
Memory Athletes

**2Lac+**  
Students Trained

**30+** World  
Record Holders

## Dr. Sushant P. Mysorekar

- Internationally Certified Intelligence Coach  
Founder - Brain Rhyme, India | Singapore  
Vice President - Indian Memory Sports Council  
Chairman - International Association of Sports & ICT, India  
Director - ACF E University (Arts & Music)  
Executive Member - Egyptian Memory Sports  
Project Initiator - Innovation Club & Book of Records

2022

Third Edition

# 36<sup>©</sup>Mind

## E-Magazine



# 360<sup>M</sup>ind

## E-Magazine

# INDEX

PG.NO	ARTICLE	
03	About Founder	- Dr. Sushant Mysorekar
04	Editor's Note	- Colonel Sushobit Kamra, Veteran
06	The Decorous	- Sushma Nandgaonkar
08	Spongy Bites	- Nisha Chheda
09	Texil Enterprises	- Rohini Patil
10	Neeru Numerologist	- Neeru Patil
12	Seed Plantation UAV	
13	Seed Plantation Drone	- Hritik Maurya, Aashutosh Gupta, Parthavi Kawa,Vinit Rathi
16	Come to India and be a part of History for a better World	- Dr. Sandeep Marwah
17	Success Stories	- BrainRhyme Anam & Adit
18	Neurobytes	- BrainRhyme

**Published by** : Brain Rhyme  
**Project Head** : Dr. Sushant Mysorekar  
**Chief Editor** : Colonel Sushobit Kamra, Veteran  
**Sub Editor** : Mrs. Madhu Jhavar  
**Content Head** : Dr.Usha Rajagopalan  
**Design By** : Mr.Ganesh Chavan  
**Publication Head** : Mrs.Vijaya Anandan  
**Research Team** : Dr. Chaitanya Hoskute  
**Research Team** : Mr. Manu Faujdar  
**Marketed By** : Mr. Jayant VKamat  
**Legal Head** : Adv.Sudarshana V. Jagdale

**Published by** : Self Publication

**Total Page** : 25

**Reach Us**

India : +91 98334 01292

HongKong : +852 5441 7070

US : +1 (973) 809-3548

Dubai : +971 52 403 6601

Malaysia : +60 12-354 2236

**Email**  
article@brainrhyme.com

**For Advertising Space**  
Call : +91 98210 40310

**Image Source**  
www.freepik.com  
www.pixabay.com

# ABOUT FOUNDER

## BRAIN RHYME



Career spanning 25+ years in training, coaching & research in the field of Cognitive Development, Management & Neuroscience. Internationally Certified Intelligence Coach holding 2 Copyrights, authored 3 Books, mentored 25+ World Record Holders, coached 100+ National & International Memory Athletes and assisted more than 2 lac students & professionals in improving their Productive skills. Presently connected with Institutions, Universities for Innovation & Research Cell at National & International level.

### BRAIN RHYME OFFERINGS

- Coaching students and professionals in identifying Neuro skills and how it can transform their intellectual capabilities.
- Strong experience in Creativity, Innovation, Customer Relationship & Problem solving skills.
- Mentoring & Coaching all age groups in creating World Record Holders.
- Incubating Innovation & Research Cells.

### OUR STRENGTHS

- Cognitive Development Programs for all age groups.
- Community Development Programs for all age groups
- Bi-Monthly E-Magazine "360Minds" covering Neuroscience Articles & Case studies, Science & Technology, Creativity, Innovation, Research & Life Skills.
- 24 x 7 x 365 day dedicated online Radio with unlimited listener's capacity.
- Dedicated Team of Trainers, Social Media & Research verticals.

### WHAT WE ARE LOOKING FOR

- Collaborations with Institutions, organization to uplift their Intellectual capabilities & gain an extra edge over others.
- Institutions who would like to conduct unique, result- oriented programs to create a brand for the next generation.
- Connect with institutions across the globe to nurture an innovative centre of excellence in the field of Neuroscience and Management.
- Provide a platform where we can showcase our students' talents and promote them.
- Students & Professionals looking to create World Records..

### OUR PRESENCE

An experienced team of around 25+ professionals (project basis) and marketing associates presently promoting us in India, US, Malaysia, UAE, Honkong & Egypt.

# Editor's Note

## ISSUE 3

They always say 'time flies' and so did it once again. We were busy till now to rejoice the suggestions, feedbacks of our launch edition and the clock kept ticking silently.

However not missing our timelines here we present to you our dear readers with the next issue of our most awaited and beautifully curated magazine or rather "Brain Rhyme eMagazine" which helps you covered holistically.

The present issue of our magazine talks about something to tickle your neurons by knowing some new facts or help you review a creative piece of contribution by one of our contributors.

Hope you savour this and have a good reading time ahead.

Once again just to remind you that your contributions, criticism, suggestion are all very important and dear to us. So please reach us for anything at our email ID....

Signing off for now!!!

With love

**Colonel Sushobit Kamra (Veteran)**  
**Editor in Chief**



- B.Tech. (Mechanical)-Gold Medal,
- M.Tech. IIT Bombay (IE& OR)
- MBA (General Management)
- PGDM (HR)
- M.Sc.

### EXPERIENCE

3+ Decades (Areas of work)

- Leadership Skills
- Business Management
- Problem Solving
- Stress Management
- Time Management
- Fight your Procrastination



**“The Brain is a Muscle  
that can move the world”**

**-Stephen King**



**Sushma  
Nandgaonkar**  
FOUNDER - THEDECOROUS.COM



#### About her:

She holds a vast experience in Finance and Operations. She has worked with eminent organisations like Sharekhan , Kotak securities and a few more. Sushma is currently chasing her dream of being a successful entrepreneur by promoting Handmade, Made in India, Sustainable products created by underprivileged woman's and skilled karigars (artisan).

She sets down her constant efforts in designing sustainable, handmade bags, accessories and home decor. She closely works with her woman entrepreneur group of friends to promote and market handmade products. She truly believes in Recycle, Reduce and Reuse. With this goal she encourages textile owners, boutique owners, sofa, curtain manufacturers to donate their excess fabric for upcycling it into numerous beautiful hand crafted products. For these efforts and initiatives she has received various prestigious awards like **"Indian Dreamers Award"**, **"Iconic Woman Award"** , **"Rajyastariya Sanman Patra for Kartuvavan Mahila 2022"**.

She currently holds Secretary position at Lions club of Bharari . She has been past President at different networking groups for woman entrepreneurs.

#### About the Brand:

Thedecorous.com brand has participated in numerous exhibitions held in Mumbai Pune and Dubai.

Till date her brand has successfully upcycled tons of waste and excess fabric. By this she has also given employment to many woman karigars. Her upcycled products have reached global and are loved by many celebrities.

By upcycling fabric, we are not only contributing in reducing waste but also trying to help in reducing soil pollution. Textile pollution is a major and global issue which everyone should be aware of. As a conscious brand we encourage every individual to upcycle and reuse as much as fabric possible.

Currently as a brand we are into manufacturing of sustainable bags , fashion accessories , home decor and stationery products like diaries , folders , pouches , bookmarks etc. Our products are widely used for eco friendly gifting. We customise as per client's requirements. We stand out as sustainable and hand made product brand.

### Aspiration:

Her goal is to empower and educate under privileged women with hands on skill making them self-sufficient to earn their lively hood. She believes every individual should get equal opportunity disregarding of its gender, caste or religion. We should always remember there is no planet B.

Lets hold hand and help each other.

***"Holding hands will just not make a chain but a chain of network and business to grow". – SUSHMA***





SCAN FOR CONTACT

If a woman decides she can do anything ! Many women, despite their talents and desires, are still stuck in their routine problems. She is today's superstar who has created her own destiny by starting from scratch and reached these miles only basis her determination, focus, strength, honesty and hard work. She too was 1 of them, who has a family, a child but inspite of routine family chores & challenges, she did not give up on her focus.

Nisha has proved that today a woman is no more an housewife but a woman who is self reliant, an entrepreneur and a home maker. She started her home-made cake business with her own brand Spongy Bites in just a span of 8 years. She is now a Cake Baking Specialist Coach for the Home Bakery Industry and is guiding many women walking this path. In uncertain circumstances like lockdown, Nisha managed to earn more than Rs. 1 lakh through her online & offline bakery classes and per month earning more then 1 lakh from bakery Business. Nisha's this journey from a home maker to entrepreneur is very inspiring. If you want to know how Nisha override her challenges and succeeded in her business. Lets learn about their inspiring and astonishing journey from

them.

Spongy Bites began its journey in 2014, as a small setup at Kandivali, Mumbai. Spongy Bites is currently having its head office at Kandivali Mumbai. From Basic cake baking learning to advance Bakery Level academy, anyone can learn A to Z of bakery & confectionery related courses. The alumni of the Institute vary from the housewives to professional artists, Till the date more than 200 students have developed their baking skills at Spongy Bites. The USP of Spongy Bites is its practical oriented training methodology where the founder, Mrs. Nisha Chheda pays personalised attention and teaches each and every student personally. The sessions schedules are flexible. There is no educational bar and age bar to join Spongy Bites institute. Spongy Bites is life-changing experience. That equips you to become a professional. Take the essential step towards your successful career, Be a part of the Spongy Bites family.

**Nisha Chheda**  
Founder, Spongy Bites







**R**ohini Patil is a Founder of Texil Enterprises. She is exclusively in business registrations and licensing. She has a team of highly qualified members who work precisely with individual clients.

**Our Aspiration**

To help budding entrepreneurs, start-ups with easy and hassle-free business registration.

**Our vision**

To reach more than 10,000+ entrepreneurs to educate them on their growth opportunities and success and to get them sustainable income from business by providing them with value added support & services.

**Our Offerings**

- Company Registrations like Pvt. Ltd, LLP, Sole proprietorship etc.
  - GST filling & registrations
  - Food Licence
  - Udyam registrations
  - Trade mark registration
  - Import export license
  - ISO certification
- and many more services.

Texil Enterprises is a company which will fulfil all your requirements right from starting a new business to supporting your business by providing various services. It is a one stop shop

for all your business needs. We are conducting seminars to give awareness of opportunities to different business licences.

**Trade Fair's & Exhibition**

**Mauritius** - We participated in 2019 Mauritius trade fair organised by Marathi Mandal Federation and awarded from their President's wife Mrs. Kobita Jagannathan

**Singapore** - "Namaste Bharat"- Global Virtual exhibition in association with De Ideaz Pvt. Ltd. Singapore.

**Dubai** - Dubai exhibition arranged by Lions club.

**Credentials**

- I am a social Entrepreneur .
- Vice President of Lions Club of International and - Working for women Empowerment. Helped more than 200+ women entrepreneurs for their livelihood.

**Appreciation & Awards**

- Indian Dreamers award,
- "Iconic women award " of CAIT MSME by Zhep Udyoginichi,
- Appreciation from Tushar Prakashan, Vasai on Women's Day.

**Rohini Patil**

Founder, Texil Enterprises



SCAN FOR CONTACT

<b>GST Registration</b>	<p>Prop. Ms. Rohini Patil          9545516350          rohini.patil2007@gmail.com          Vasai Road, Mumbai, Maharashtra, India</p>	<b>Food Licence</b>
<b>Udyam Registration</b>		<b>Shop Act License</b>
<b>Income Tax e-filing</b>		<b>Import Export Code (IEC)</b>
<b>EPF Registration</b>		<b>Digital Signature</b>
<b>Patent Registration</b>		<b>Company Registration</b>
<b>ESI Registration</b>		<b>Trade Mark &amp; ISO</b>
<b>200+ more services available in all over Maharashtra</b>		



**T**ell me your date of birth & I will tell you about yourself. If I say this to you will tell me right away that don't say anything or don't lie. How is this possible ?? Right, but wait, it is possible by Numerology.

Numerology is one of the most important branches of astrology. Numerology divination has the same value & importance in astrology like horoscope, palmistry, face reading & pulse reading. Your nature & behaviour can be determined by your numerology number. Numerology no. is determined by the date of birth on which a person is born. If the date of birth of a person is one digit, that is between 1 and 9 then that date is the numerology number of that person. If the date is two digits that is, between 10 and 31 then the digits of that date are added to form one digit and that digit is the numerology number of that person.

One can verify one's own future on the basis of numerology. It also helps us to understand many aspects of our nature. Numerology is the science of numbers. Numbers also have energy and it affects people. Got it ?? Today we are talking much about Numerology is because today's entrepreneur is NEERU NUMEROLOGIST Neeru Patil. She is the one who loves numbers, talks about numbers for hours & hours, with the help of numbers she has revealed many aspects of our nature and future. she is our friend Neeru Patil.

**NEERU NUMEROLOGIST** has designed a formula by doing research in numerology & only she has got that formula in the world. The date of birth that God has given us is the secret of our birth. God has given us the good luck of our life.

Our date of birth is the planet & that planet is also the lord of our birth. God has created us with the help of planets. So we have to connect our inner planets & not the planets in sky. Said by NEERU NUMEROLOGIST.

Neeru ji had made her Patrika first with the help of the formula she has invented. She has experienced the change in herself & got amazing, unbelievable experiences in life. Then she had made the Patrika for her closed once. The positive changes in them also made her realize that this is indeed a magical formula. This formula can change the lives of many and this is where Neeru ji found her life goals. The result of 690 of Patrika she has made till date is Tremendous.



**Neeru Numerologist**  
Founder of Magical  
Numerology Formula

M. +91 83560 08039  
E. neerunumerologist24@gmail.com

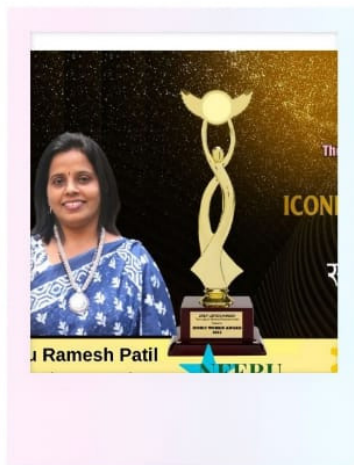

The Patrika she has made have completely changed the lives of many people. Neeru ji gives Training before making the personalized Formula. Because the formula also works only when you are ready to work on yourself. Most of the time we want everything without doing anything. If you want the good luck of your life, you have to work hard. That is why Neeru ji make the Patrika of those who work on themself. This formula is beneficial for everyone from young to old. We all have a date of birth and therefore this formula is beneficial to all. Neeru ji as completely immersed herself in this work. The positive changes happening in people's lives are more satisfying to her than the rewards she gets from her work.

Neeru ji always says this to everyone that, 'Keep doing good deeds(Karma) honestly, you will get good luck of your destiny.' This magical formula of NEERU ji gives you all the happiness in your destiny. You do not have to choose wrong path to achive & get all your happiness of life. You should be able to use good luck of ur your destiny.

We can say that Narayanji's blessings is on Neeru ji's head and Naraynji is the one who gets this beautiful work done by her. Neeru ji came to ZHEP 12 years ago. Although she does not fit into our group of other entrepreneurs but her work is very different from others. Her work is gaining a distinct identity through ZHEP. Best of luck to this entrepreneur who is a magician of numbers.

## ACHIEVEMENTS

In occasion of women's day in march 2022 i received MAHILA RATN AWARD for my MAGICAL NUMEROLOGY FORMULA from ZEP UDHYOGINICHI GROUP and Thanku PURNNIMA MAM for giving this honour to me.

## TARGETS

In the next 3 years, I want to spread this MAGICAL NUMEROLOGY FORMULA all over the world and it is my TARGET to create NEERU MAGICAL NUMEROLOGY FORMULA for all the people of the world and I promise to fulfill it by the grace of Narayana.

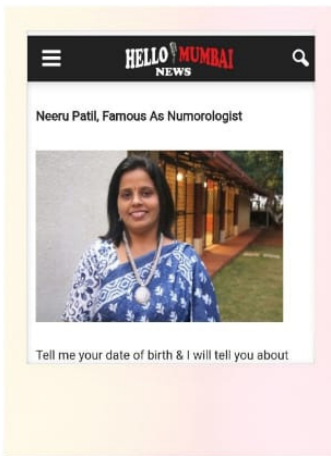

# Seed Plantation UAV

There is far too much advancement in science and technology in the modern day. However, the rise in natural disasters is the one where we as a species are still trailing in our ability to foretell when and where something can occur. But if we look closer, we may see that the problem's solution is already there: trees. In this project, we're going to focus primarily on the problem of Deforestation of mangroves. As said, we are in a severe threat of climate change, global warming, and rising sea level which affects the city specially the ones near the coastal region. Since the rising sea level leads to land erosion, there where mangroves help us they hold the soil and prevent the erosion caused by it.

This mangrove forest helps to manage the sea level and reduce global warming; they are also the oxygen tower for an entire city. Deforested Mangroves/ Marshy lands are inaccessible to human reach. Physically scattering seeds in these inaccessible locations is not possible, the unmanned aerial vehicle (UAV) would scatter seeds on bare marshy ground where there are fewer mangroves.

UAVs can be employed readily in these situations where labour and equipment are difficult to operate. As said by our Prime Minister Narendra Modi in COP26 UN-led summit on climate change that India will achieve net zero carbon emissions by 2070, our project will help us to achieve the same. Our project also stands on the sustainable development goals (SDGA) agenda (2030) set by the united nation organization. The project will be making the process of afforestation a simple process with the help of our drone and dropping mechanisms installed in it, the seeds will be dropped on the desired location and then its growth will be monitored remotely.



Figure 1: Virendra Tiwari Executive Director of Mangrove & Marine Bio-Diversity Foundation of Maharashtra



# SEED PLANTATION DRONE

White Paper by KJSIEIT,  
SION

Hritik Maurya, Aashutosh  
Gupta, Parthavi Kawa,  
Vinit Rathi

## Introduction

There are far too much advancement in science and technology in the modern day. However, the rise in natural disasters is the one where we as a species are still trailing in our ability to foretell when and where something can occur. But if we look closer, we may see that the problem's solution is already there: trees. In this project, we're going to focus primarily on the problem of Deforestation of mangroves. As said we are in a severe threat of climate change, global warming, and rising sea level which affects the city specially the ones near the coastal region. Since the rising sea level leads to land erosion, there where mangroves help us they hold the soil and prevent the erosion caused by it. This mangrove forest helps to manage the sea level and reduce global warming; they are also the oxygen tower for an entire city. Deforested Mangroves/ Marshy lands are inaccessible to human reach. Physically scattering seeds in this inaccessible locations is not possible, the unmanned aerial vehicle (UAV) would scatter seeds on bare marshy ground where there are fewer mangroves. UAVs can be employed readily in these situations where labour and equipment are difficult to operate.

The goal of the initiative is to make afforestation simple processes. The project's main objective is to implement a drone that could help plant or drop seeds in places that are inaccessible to humans. To make the task easier and prevent unneeded mistakes, the project was implemented in stages. To comprehend the complexity that can be encountered in the stage 2 advance implementation, stage 1 includes the prototyping of the full mechanism in a modest version.

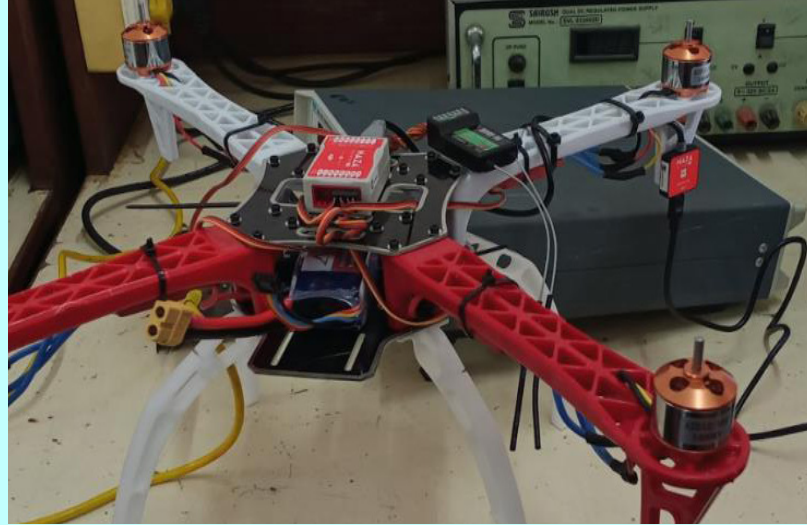

## Field Visits

To understand mangrove plantations, geographical condition and Drones role there was a need for field visit. Hence, on 09 April, 2022, the team visited few sites of Mithi river creek near Mahim Causeway and Bandra-Kurla Complex arranged by VinayKumar Awate, Matoshree NGO, under the guidance of Dr. Jayashree Khanapuri, Head of Department, Electronics and Telecommunication Engineering. Dr. Suresh Ukarande, Principal, KJSIEIT, Sion. Following is the list of entire team of Field Visit.



## Technical details

Now let's talk about the specifics of the two-rotor throwing mechanism. We'll be using two rotors that spin at a rate of 8000 rpm each, coupled with a hollow pipe that will properly convey the seeds toward the rotor. The seeds will then be annihilating by the rotors in a straight line, easily penetrating the soil in the process. A gate that opens and closes will be present, along with a servo motor, an IR sensor, and other components. The gate will open and close in response to commands sent to the sensor.

Now, in the second mechanism, gravity will be used without the usage of an additional or external rotor. For the seeds to fall into the field properly, one or two at a time, the latch will contain a servo motor for the opening and closing mechanism.

## Inclusion of Modular Design

The machines are made to be detachable, and the mechanism can be adjusted or modified by the needs of the user or the environment. The concept behind creating such a system was to use the gravity fall mechanism in ideal environmental conditions and the throwing mechanism with two rotors in tough or adverse environment.'

Following the conclusion of stage 1's implementation and testing, we moved on to stage 2's implementation. At this point, we finished designing the original drone and assembling the parts that will be used to accomplish our goals. We encountered numerous difficulties implementing the concept due to aerodynamics, its strength, and other aspects. We did a lot of research and development on numerous designs, including the dome design, hexagonal design, and square design, because we need to be able to carry a lot of weight with our drone, which will be between 3kg to 5 kg.

## Frame Design

After thorough investigation and study, we settled on a universal design for the building's ultimate frame. We decided to create a dual-jointed arm to increase the strength of the arms and enable them to withstand the tension and vibration that the motors produce when they are operating. To better understand our design and the amount of thrust, pressure, tension, and vibration that it can withstand, we first implemented it using PVC tubing. After creating the structure in many dimensions, we comprehended and recognized our errors. As a result, we learned about our minute errors, which enabled us to improve and perfect our structure. We finally settled on one dimension as our preferred dimension for on-going design after numerous dimension modifications and inspections. Following that, we kept working on our design factor and concentrated on our major goal of giving our chassis adequate strength so that it can withstand all the stress, vibration, etc. listed above according to its needs.

The optimal weight that we discovered was approximately 12 to 13 kg, which satisfied our demand since the maximum load that our motors can take off is 10 kg each arm, after we finished the design work of the arms. We kept testing our model in the 3D program Fusion 360 to discover more about the design's advantages and disadvantages.

## Experimentation and outcome:

Battery design is very crucial to support maximum flight time for drone hence we started working on creating a new drone battery to extend flight time to improve flight performance. So, after looking at various battery types, we chose to test lithium-ion batteries because they were lighter and had a higher power rate, all of which were appropriate for our drone. The ability to charge and discharge power as well as its environmental tolerance was its key advantages. We created a 3S battery for our drone, which has a 12v 5amp power output, after getting our design ready.

We began testing our battery on the drone after the design and implementation of the battery were complete. After testing, we determined that the lithium-ion battery was more suitable for our drone in terms of power and weight, weighing between 30 and 35g less than the lithium polymer battery, which was about 150g in total.

After that, we put our prototype to the test with the mechanism and the battery to determine the advantages and disadvantages of our overall design. We failed on our first flight because the drone's weight was not distributed properly

During a subsequent flight, we discovered that the drone's mechanism, which was fixed downward, had caused an aerodynamic failure in the prototype. After making all the necessary repairs, our drone was prepared for a successful last flight. For our records, we kept track of every success





### Chassis Design

After finishing the prototype, we began designing the chassis—or the body—of our bigger, more important drone. Due to the low cost and wide availability of PVC tubing, we first created the concept using it

After using PVC to create the entire design, we discovered that it was appropriate and ready to use. It could support a weight of 12 kg per arm, which was sufficient and met our need of 10 kg per arm. The next step was to test the stability and aerodynamics of our design, and for this, we used some simulation software.

### Conclusion

This Project undertaken by Matoshree NGO and Electronics and Telecommunication Engineering Department will help to Design drone that is Economical, Modern and equipped with advance technology to the required Job. This project also in line with Sustainable Development Agenda (2030) United Nation. We give our sincere thanks to Dr. Jayashree Khanapuri , Head of Department , Electronics and Telecommunication Engineering Department We also Extend are sincere thanks to Dr. Suresh Ukarande Principal and management of KJSIEIT for giving us opportunity to work on this project.

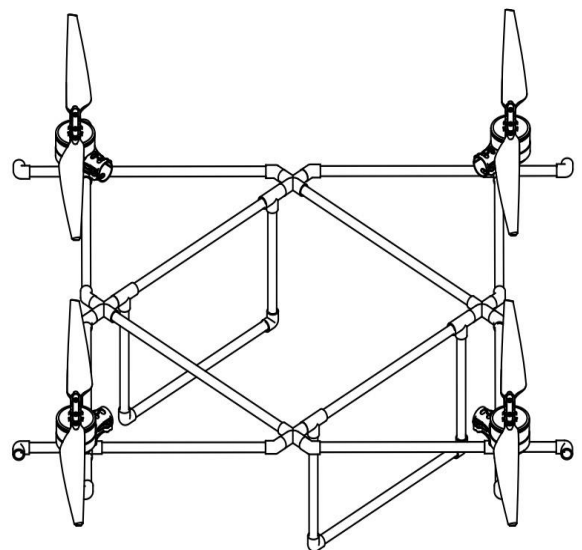
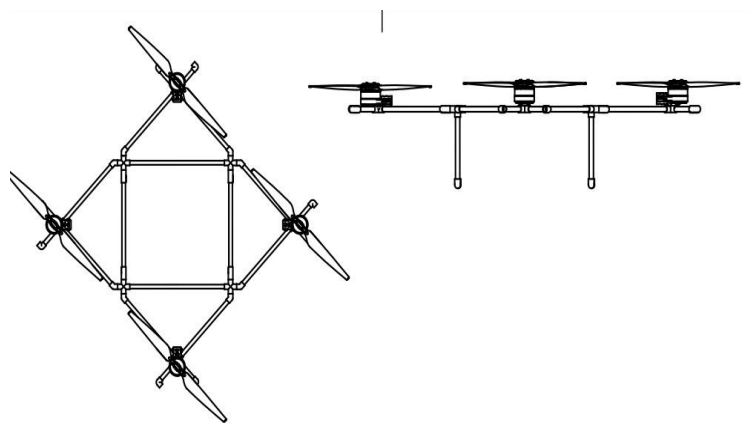

# Come to India and be a part of History for a better World...

**U**nder the patronage of the Ministries of Education and the External Affairs of the Government of India, the 1st Global South Universities Association (GSUA) Summit Awards & Expo will be held on the 28th – 30th of October 2022 at the Vigyan Bhawan and the Le Meridien Hotel, in New Delhi.

Highlight of the august occasion, commemorating the 77th anniversary of the founding of the United Nations, is the inauguration of the Global South Universities Association (GSUA) and launch of the Global South Centre for Research Innovation Peace and Technology for Sustainable Development (G-SCRIPTS-D).

Similar to Prime Minister Narendra Damodardas Modi's call to investors at the Dubai Expo to be part of India's growth story, the Hon'ble Minister of State for Education and External Affairs, and Chief Guest of the GSUA Summit, Dr. Rajkumar Ranjan Singh, has sighted the great opportunity to discover, partner and to progress by coming to India. The Hon'ble Minister with two portfolios, called on investors, educators, innovators, researchers, policy makers, change makers and administrators to join India and the Global South in this historical exploit.

Fully endorsed by the Associations of Universities for Africa, Arab and the Asia Pacific, the two distinct initiatives of the Africa Asia Scholars Global Network (AASGON) are structured to ameliorate education and rebuild the bricks of our 'fractured world' as proclaimed by the World

Economic Forum in Davos, and more significantly, close the ever increasing 'Global North-South Divide'.

As envisioned for the GSUA 22 Summit, new openings, connections, knowledge and breakthroughs are imminent for the hundreds of participants, partner institutions and corporate sponsors, the founder of AASGON and group executive president, Abdul 'Dewale Mohammed, remarked, stating this is a work in progress which has been on with 7 good years of intensive research and consultations, mainly across the Global South.

## **For more information, press only:**

Dr. Sandeep Marwah, Chairman GSUA Media 22 Media Committee

+919899370800

+44 7443950254

info@aasgon.com

For more information on GSUA'22:

Website <http://aasgon.com>





# NEUROBYTES



**C**heers to all the hard working women keep working hard towards your dream and one day your dream will come true. To achieve any of your dream or goal first you have to dream big and start

taking small steps towards it daily. For this thing to happen you have to keep in mind few lines “ be bold enough to use your voice, be brave enough to listen to your heart, be strong enough to create the life you deserve.

First and foremost I would like to pay my heart felt gratitude to Brain Rhyme for giving me an honour to be their artist.

I Anam Syed was born brought up in Akola which is located in maharashtra. I enjoy learning new things like drawing as I was interested in Painting since Childhood.

I have MSc in molecular Biology and looking for PhD.I am a night thinker and day dreamer ,very hard working and always ready to upgrade by adding new learnings on a daily basis .

Drawing and Painting is my passion and Hobby since childhood that is apart from my educational background. As my educational qualifications are in molecular biology so I look forward to take admission in PhD and will persue my carrier as a Scientist in molecular biology laboratory.

**Anam Syed**  
**Artist, Brain Rhyme**



**H**i, My name is Aditi Nandi from Siliguri, West Bengal and i'm 28 years young.

I'm thankful that have been given this wonderful opportunity by Brain Rhyme to produce a

column that express myself in unique ways. Through all my life i have been a challenge seeker, i left home for higher studies when i was in class 11 and been on my own since then. As a B-tech graduate in ECE dept completed in 2017 , i wanted to pursue something that is related to robotics and closely connected to my core studies and i love AI and ML and humanoid robots and always wanted to build one.

I started my professional career as a robotics trainer and curriculum developer for K10 sector in 2018, trained for robotics, STEM,IOT and coached for international robotics competition, soon flourished more in the my professional life with help of great CEO's and my dear managers, as i always wanted to manage a team as i

was a team player, soon learned skills to upgrade my professional life with team management, with operation and marketing skills and become a Program Manager at Toppr technologies,Hyderabad.

I love to write short and long writeups as i believe “when voice can't express your feeling, your words will” .

I have been a part of various anthologies, story books, created many curriculum for teaching, coding to kids and recently started creating contents for brain study for Brain Rhyme. I have been writing all my life along with my another hobby i.e arts and crafts, as they help to think better and be in creative line and it has been always my support as creative peoples are never sitting idle.

So, a little about my life might have entertained you or might have encouraged some of you to keep reaching out for what you love. As if you love what you do, you never go to work daily rather you enjoy every bit of it.

**ADITI NANDI**  
**Content Creator & Program Manager**

# NEUROBYTES 1

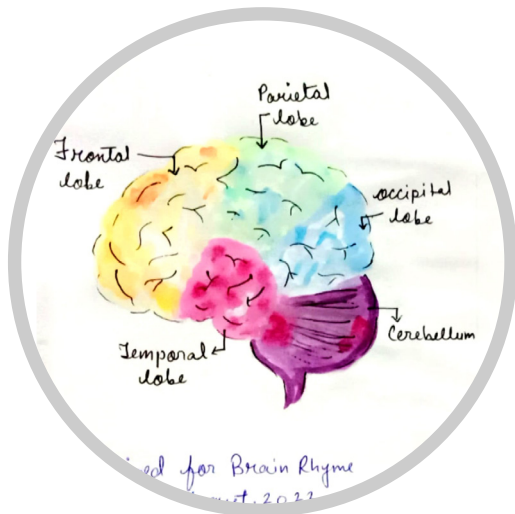

The brain, a specialized organ is responsible for every thought, every feeling & emotion, and the vast majority of our actions to regulate the body. Its unique (and complex) three-dimensional architecture plays an important role in deciding upon and issuing those important commands.

Each part of the brain's intricate configuration works together to govern sensation and perception, information processing, and the initiation of a wide variety of behaviors—and helps us make sense of the world around us.

The complexity of a brain is much more than than our internet connections, and understanding it could be a mind blowing experience.

While a complete discussion of neuroanatomy is worthy of a thick textbook full of elaborate illustrations, come discuss and learn some of the basics.

# NEUROBYTES 2

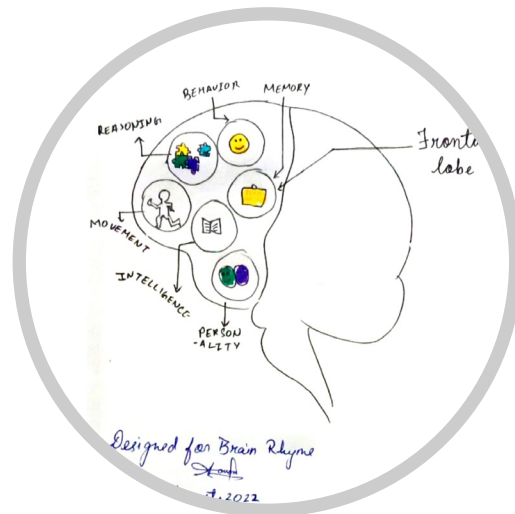

## Do you know how the Frontal Lobe of the brain is essential for us?

The frontal lobe is the part of the brain that controls important cognitive skills in humans, it's the "control panel" of our personality and our ability to communicate such as

- Emotional expression or Behaviour- for happy,sad,angry,confuse moods.
- Problem-solving or Reasoning- help us to calculate complex situation and take decisions.
- Memory- short and long term life actions memories.
- Language- Broca's area, a region in the frontal lobe, helps us put thoughts into words, helps to learn and remember our communicative languages.
- Movement- The frontal lobe houses the primary motor cortex, which helps control voluntary movements, including walking and running..

There are more such facts and information you can grab to know how our brain is the strongest network system.

**Subscribe and follow Brain Rhyme for more.**

#frontallobe #behaviour #broca'sarea  
#cognitiveskills #memory #movement  
#networksystem #brain #neuroscience  
#brainrhyme #neuroanatomy

## NEUROBYTES 3



Neuroscience does brain imaging and behavioral experiments to examine how creative thinking works in different contexts and domains, from the arts to the sciences to everyday life.

- Creativity is essential for the arts, for new inventions, and for human expression.
- Since creativity is among one of the most complex of human behaviors, it likely requires the coordination of multiple brain regions and types of thinking. Because creativity is so complex, it seems naive to think that creativity can be localized to a single region in the brain. In fact, only a few neuroscience studies have tried to investigate the regions of the brain responsible for creativity.
- For a long time, scientists thought that creativity was processed only in the right hemisphere (side) of the brain. However, studies that looked at the activity in the brain while people were doing creative tasks, or in patients who had brain damage that resulted in difficulty with creativity showed that an area of the brain called the frontal cortex was associated with creativity. This seemed to make sense because the frontal cortex processes the previously mentioned cognitive processes (for example, working memory, abstraction, planning, and cognitive flexibility).
- Now a question arise that Can creativity be enhanced?

#neuroscience #brainrhyme #studyofbrain  
#trainingbrainright #factsabouthumanbrain

## NEUROBYTES 4



### How our BRAIN reacts OR responds ?

Suppose I meet you & tell you, while travelling, when I came out of the car , I lost my wallet. It had few currency notes, debit & credit cards, few imp visiting cards , license.

#### ***How are you going to react / respond to this situation.***

1. You will console / pity me.
2. You may even give me a lecture.
3. You may even say "bad luck".
4. Some may even say that's it Good luck !!

Words play a major impact & we immediately analyse, suggest, comment & provide consultancy.

#### ***Now how many of us will think like this ...***

1. Are you sure that you lost your wallet when you came out of the car.
2. Are you sure you had wallet in your pocket.
3. Have you checked the car before moving out.

These are called reflexive behaviour responses, who visualise the hidden gaps within the sentences & think on the solution rather than working on problems.

#brainrhyme #brain  
#thoughts #perspective

## NEUROBYTES 5

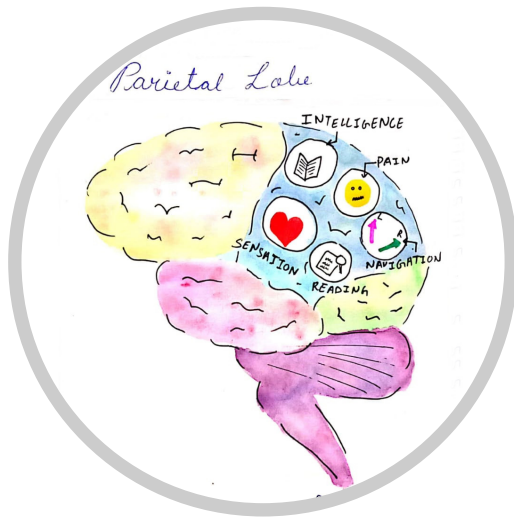

### DO YOU KNOW

Which lobe is located at the upper back part of brain & if any damage occurs to this which kind of medical issues would arise?

This is one of the four major lobe of the cerebral cortex in the brain of mammals. This part is positioned at upper back area in the skull behind the frontal lobe and central sulcus. It processes sensory information it receives from the outside world, mainly relating to touch, taste, and temperature.

This relies heavily on many other areas of the body to receive information. For example, the skin and nerves in the skin play a large part in detecting sensory information and delivering it to this part.

**FACT:** A person's dominant hand will often determine which side of this lobe is more active. A person who is right-handed may have a more active left hemisphere of this lobe. The left lobe tends to deal more with numbers, letters, and symbols. The right hemisphere may be more active in people with a dominant left hand. This hemisphere is associated with image interpretation and spatial relationships.

Share your thoughts. More details coming up in our next NEUROBYTE !!!

#brainrhymes #brainstudy  
#neuroanatomy #learnaboutbrain

## NEUROBYTES 6

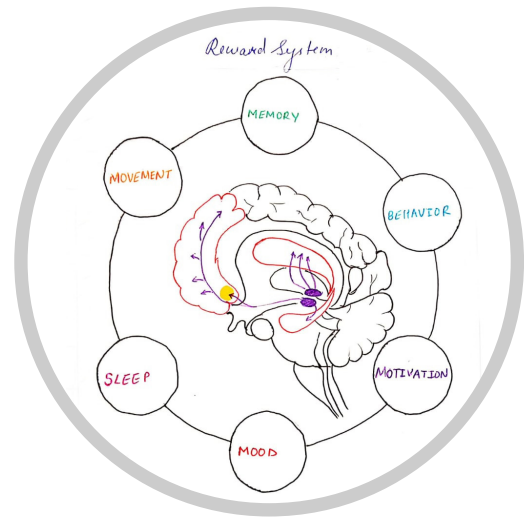

Dopamine is a type of monoamine neurotransmitter. It's made in your brain and acts as a chemical messenger, communicating messages between nerve cells in your brain and your brain and the rest of your body. Dopamine also acts as a hormone.

**Dopamine plays a role in many body functions. As a neurotransmitter, dopamine is involved in:**

- Movement
- Memory
- Attention
- Sleep
- Mood
- Learning
- Lactation
- Pleasurable reward and motivation
- Behavior and cognition

Dopamine is part of your reward system. This system is designed, from an evolutionary standpoint, to reward you when you're doing the things you need to do to survive-eat, drink, compete to survive and reproduce.

*Example:* if one suddenly gets hurt while cutting vegetables, the pain they feel seeing blood flow is a sign of message sent from the area to brain to make one feel pain and react to it.

Share more examples or how we can understand dopamine is a reward system for us?

Post you comment below!!

Keep reading!

#neuroscience #neuroanatomy #brainrhyme  
#brainstudy #brainfacts #dopamine  
#rewardsystem

# NEUROBYTES 7

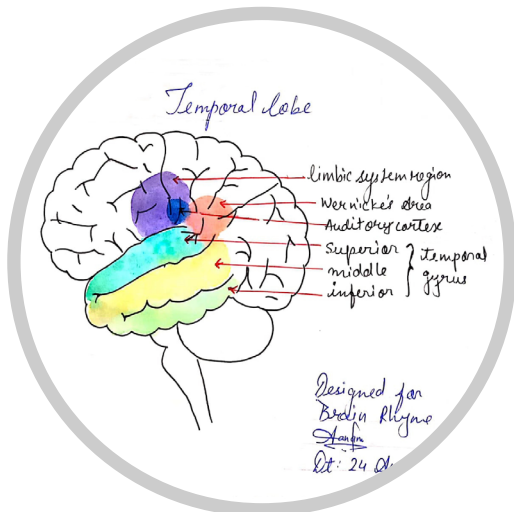

## TEMPORAL LOBE - PART 1

Answer to our NEUROBYTE 5 -Parietal Lobe, damage to this may cause tumour-like medical issues.

The temporal lobe is located on the side of the head behind the ears (temporal means "near the temples, which relates to their positioning in the cerebrum").

The temporal lobes are the second largest lobe accounting for 22% of the overall brain's volume. The outer surface of the temporal lobes is called the neocortex. They are most commonly associated with processing auditory information and with the encoding of memory.

The temporal lobes are also believed to play an important role in processing affect/emotions Language and certain aspects of visual perception. The dominant temporal lobe, which is the left side in most people, is involved in understanding language and learning and remembering verbal information. The non-dominant lobe, which is typically the right temporal lobe, is involved in learning and remembering non-verbal information (e.g. visuospatial material and music).

- Symptoms that show during temporal lobe damage:
- Difficulty in understanding spoken words
- Disturbance with selective attention to what we see and hear
- Difficulty with identification and categorisation of objects
- Difficulty learning and retaining new information
- Difficulty in recognising faces
- Emotional disturbance (e.g. Aggressive behaviour)

Do you know what if someone has difficulty in recognising faces, what this neurological condition is called?

Post your answers below or wait for the next NEUROBYTE!!

## TEMPORAL LOBE PART - 2

Temporal Lobe part -1 Answer: Prosopagnosia  
There are many substructures, structurally divided into the superior, middle, inferior and medial gyri within the temporal lobes which have specific functions.

**Key structures that are part of the temporal lobe include:**

- Wernicke's area - responsible for processing and giving meaning to speech and the written word
- Broca's area - responsible for a person's ability to speak and use language with fluency.
- Limbic system - responsible for motivation, emotion, learning, and memory.

These structures also span other lobes. For example, Wernicke's area extends into the parietal lobe, and Broca's area is part of the frontal lobe.

**The major functions of the Temporal lobe are:**

- Visual memories
- Processing sensory input
- Language Recognition
- New memories

The inner part of the temporal lobes is the older part of the cortex, also known as the limbic system, which includes the hippocampus and the amygdala. The temporal lobe communicates with the hippocampus and plays a key role in the formation of explicit long-term memory modulated by the amygdala

Hippocampus - The hippocampus is a major component of the brain of humans and other vertebrates and plays important roles in the consolidation of information from short-term memory to long-term memory, and in spatial memory that enables navigation.

Amygdala- Plays a primary role in the processing of memory, decision-making, and emotional responses.

Do you know the name of the medical condition of a person experiencing difficulty in reading?

There are other major neurological conditions which may occur due to damage of the temporal lobe, share below if you know about them to spread awareness!!

#neurology #brainstudy #neuroanatomy  
#partsofbrain #temporal\_lobe #brainrhymes  
#braindimensions #knowledgeaboutbrain

## Our Team - Global



## Our Expert Team



Col. Shobit Kamra



Dr. Dilip Patil



Dr. Jagdish Parikh



Mr. Dilip Mukerjea



Mr. Dilip Tikle

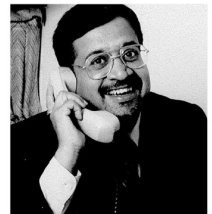

Dr. Chaitanya Hoskute



Poster made by Rutva

# A Newspaper For Children

Build reading habits among children through a printed monthly newspaper

Since 2012

Current Affairs, National/International News, Activities, Stories, GK, Puzzles and More.

Content simple, relevant to children, supported with lots of illustrations, pictures.

Crisp layout, optimum font size for ease in reading.

Printed on good quality art paper (20 pages).

Sent anywhere in India by courier.



For annual subscription & details, call/whatsapp **9823185306**

WHO CAN ADMIT? VISION & MISSION	FACILITIES
<p><b>SAINIK SCHOOL &amp; NAVODAYA COACHING</b></p> <p>Register your child now!</p> <p>Visit office to check child's eligibility for the Entrance</p>	<ul style="list-style-type: none"> <li>• Study materials</li> <li>• Past papers</li> <li>• Mock papers</li> <li>• Web access</li> <li>• well trained Teacher's</li> </ul>
<ul style="list-style-type: none"> <li>• Taking admission for 4th, 5th standard</li> <li>• 1&amp;2 years of coaching for better results</li> <li>• Children are trained to be independent individuals and are able to solve problems according to their developmental age.</li> </ul>	
<p>vasista edventures c/o Insight commune SS layout, B block, indoor stadium main road Davangere</p> <p>7899049966 , 8904062555</p>	

**Navodaya and Sainik Coaching Batches will Start from Online/ Offline : 3rd July 2022**  
**Hurry up Limited seats for this Batches..**  
**Few seats left**



# BRAIN RHYME

Coaching | Championship | Innovation | World Records

in association with

## Jarayu Ayurveda

# FESTIVALS, FOOD & AYURVEDA

### 1 Day Panchakarma in Ayurveda to detoxify your body

All those suffering from the following diseases

- Obesity/weight gain
- PCOD
- Rheumatoid Arthritis
- Weight loss
- Joint pain/Arthritis
- Gout

People from the age group  
of 18 to 70 years can register.

People suffering from any health issue  
as well as healthy individuals can join.

WHAT  
WE SHALL  
COVER

- Vamana
- Virechana
- Basti
- Raktamokshan
- Nasya

## LET US REJUVENATE AND DETOXYFY THIS FESTIVAL SEASON



**Dr Anuja Salwatkar-More**  
B.A.M.S



**Dr Tejas More**  
B.A.M.S, M.D



**Dr.Sushant P.Mysorekar**  
Cognitive Coach & Consultant

### WHEN

**Sunday 18th September**  
**at 9:00 AM-6:00 PM**

**FEES Introductory Price Rs.5000/- Only**

## Jarayu Ayurveda & Panchakarma Clinic

Address : 001, Manasvastu building, Khopat, Thane west.

Call for More Details : +91 9833401292 / 7588800354 / 8928287182



# We love suggestions and would be happy to perform to match your heart's rhythm!

## E-Magazine inclusives : you can send us

- Informative Article(IR)
- Promotional Article(PA)
- Advertisements (JPG image)
- Quarter Page (QP)
- Half Page(HP) / Full Page(FP)
- Presentation(Full Page) – PFP
- Award | Certificate(AR)
- Book Promotion - Author Page (AP)

Once in 2 Months : 6 Magazines X Rs.80	Rs.480/- per year
BONUS for first 100 Subscribers	One Article 300words OR One Artwork OR Free 60mins Session on Neuroscience with ExpertCoach.

\*Disclaimer: The article's thoughts and content are totally contributed by the respective Authors and BrainRhyme does not assume any responsibility for it.

Name : BRAIN RHYME  
Current Account. No : 006100100202700  
Name of the Bank : Saraswat Cooperative Bank Ltd.  
Branch : Madhukendra, Dadar (West)  
IFSC Code : SRCB0000006 ( 6 Zero's)

15  
भारत  
INDIA

जवाबी  
REPLY

पोस्ट कार्ड POST CARD

I wish to subscribe  
for the Magazine

Name \_\_\_\_\_

Address \_\_\_\_\_

Contact No \_\_\_\_\_

Email ID \_\_\_\_\_

पिन PIN [ ] [ ] [ ] [ ] [ ] [ ]

Subscribe



# BRAIN RHYME

Coaching | Championship | Innovation | World Records

